

## STEP-BY-STEP GUIDE FOR INSTALLING CHAMELEON ACOUSTIC INDUSTRIAL SHADE

**READ AND FOLLOW ALL SAFETY INSTRUCTIONS!**

**SAVE THESE INSTRUCTIONS AND DELIVER TO OWNER AFTER INSTALLATION**

- To reduce the risk of death, personal injury or property damage from fire, electric shock, falling parts, cuts/abrasions, and other hazards please read all warnings and instructions included with and on the fixture box and all fixture labels.
- Before installing, servicing, or performing routine maintenance upon this equipment, follow these general precautions.
- Installation and service of luminaires should be performed by a **qualified licensed electrician**.
- Maintenance of the luminaires should be performed by person(s) familiar with the luminaires' construction and operation and any hazards involved. Regular fixture maintenance programs are recommended.
- It will occasionally be necessary to clean the outside of the refractor/lens. Frequency of cleaning will depend on ambient dirt level and minimum light output which is acceptable to user. Refractor/lens should be washed in a solution of warm water and any mild, non-abrasive household detergent, rinsed with clean water and wiped dry. Should optical assembly become dirty on the inside, wipe refractor/lens and clean in above manner, replacing damaged gaskets as necessary.
- **DO NOT INSTALL DAMAGED PRODUCT!** This luminaire has been properly packed so that no parts should have been damaged during transit. Inspect to confirm. Any part damaged or broken during or after assembly should be replaced.
- Recycle: For information on how to recycle LED electronic products, please visit [www.epa.gov](http://www.epa.gov).
- These instructions do not purport to cover all details or variations in equipment nor to provide every possible contingency to meet in connection with installation, operation, or maintenance. Should further information be desired or should particular problems arise which are not covered sufficiently for the purchaser's or owner's purposes, this matter should be referred to Acuity Brands Lighting, Inc.



**WARNING**  
**RISK OF ELECTRIC SHOCK**

- ✓ Disconnect or turn off power before installation or servicing.
- ✓ Verify that supply voltage is correct by comparing it with the luminaire label information.
- ✓ Make all electrical and grounded connections in accordance with the National Electrical Code (NEC) and any applicable local code requirements.
- ✓ All wiring connections should be capped with UL approved recognized wire connectors.



**WARNING**  
**RISK OF BURN**

- ✓ Allow lamp/fixture to cool before handling. Do not touch enclosure or light source.
- ✓ Do not exceed maximum wattage marked on luminaire label.
- ✓ Follow all manufacturer's warnings, recommendations and restrictions for: driver type, burning position, mounting locations/methods, replacement and recycling.



**CAUTION**  
**RISK OF INJURY**

- ✓ Wear gloves and safety glasses at all times when removing luminaire from carton, installing, servicing or performing maintenance.
- ✓ Avoid direct eye exposure to the light source while it is on.



**CAUTION**  
**RISK OF FIRE**

- ✓ Keep combustible and other materials that can burn, away from lamp/lens.
- ✓ Do not operate in close proximity to persons, combustible materials or substances affected by heat or drying.

- ✓ Never connect components under load.
- ✓ Do not mount or support these fixtures in a manner that can cut the outer jacket or damage wire insulation.
- ✓ Controls for dimming, auto-sensing, or remote control of a luminaire that are not factory-wired to the luminaire must be checked for compatibility with the luminaire prior to installation. LED fixtures must be powered directly off a switched circuit.
- ✓ Unless individual product specifications deem otherwise: Do not restrict fixture ventilation. Allow for some volume of airspace around fixture. Avoid covering LED fixtures with insulation, foam, or other material that will prevent convection or conduction cooling.
- ✓ Unless individual product specifications deem otherwise: Do not exceed fixtures maximum ambient temperature.
- ✓ Only use fixture in its intended location.
- ✓ LED products are Polarity Sensitive. Ensure proper Polarity before installation.
- ✓ Electrostatic Discharge (ESD): ESD can damage LED fixtures. Personal grounding equipment must be worn during all installation or servicing of the unit.
- ✓ Do not touch individual electrical components as this can cause ESD, shorten lamp life, or alter performance.
- ✓ Some components inside the fixture may not be serviceable. In the unlikely event your unit may require service, stop using the unit immediately and contact an Chameleon Lighting representative for assistance.
- ✓ Always read the fixtures complete installation instructions prior to installation for any additional fixture specific warnings.
- ✓ Always ensure that the electrical distribution system is up to NEC (and any applicable local code) requirements.
- ✓ Verify that power distribution system has proper grounding. Lack of proper earth ground can lead to fixture failure and may void warranty.

## STEP-BY-STEP GUIDE FOR INSTALLING CHAMELEON ACOUSTIC INDUSTRIAL SHADE

1. Remove fixture components and parts pack  
Note: Turn off power at circuit breaker box!
2. **Remove Wireway Cover Assembly by unscrewing 4 screws At the ends of the fixture. You may need to remove the louver. If so GENTLY pull up on both sides of the louver at each cell. To avoid damage DO NOT PULL UP FROM ONE END**
3. **Determine appropriate knockout** on Housing assembly (1) for removal in relationship to incoming power supply. (Knockouts are located on each end and back of the fixture.)

### To remove knockouts:

Place standard screwdriver on edge of circle (on opposite side from retaining tabs) and gently strike with hammer. Grip edge with pliers and flex back and forth until removed. **See Fig. 2.**

4. **If using romex strain relief bushing or power cord strain relief**, install the bushing into the open hole.
5. **Insert house power supply cable** through open hole or strain relief bushing.
6. **For surface mounting position the Fixture Housing against** the mounting surface and with a pencil, mark the screw hole locations to be located at the narrow section of the keyholes. **See Fig. 3.**
7. **Using a drill with a 1/16" drill bit**, make two small pilot holes at the marked screw hole locations. If drill bit does not encounter a stud or wood surface, use toggle bolts or suitable fastener depending on structural conditions. If drill bit does encounter wood surface, use #10 wood screw.
8. **Partially install the Mounting Screws.** Position the Fixture Housing against the mounting surface with the screw heads through the keyhole mounting holes. Slide the fixture until the screw heads are through the narrow section of the key holes. Finish tightening the screws to secure the fixture against the mounting surface.
9. **For suspension via aircraft cable attach the cable gripper in to the mounting holes that are installed with the PEM Nut inserts**
10. **Attach other end of cable assembly to building with supplied hardware**

11. **(Contd) between fixtures.**
12. **For cable mounting use coupler/joiner box**  
Line up with Knock out in back of fixture  
And attach 4 supplied screws to mount box to back of fixture. Wires are run through the box to supply power between fixtures  
This will now also be the mounting position for the cable mount between fixtures.
13. **Ensure all electrical connections are made** and replace wireway covers.

### WIRING AND FIXTURE OPERATION CAUTION:

**Connect fixture to supply wires rated for at least 90°C (194°F).**

**Do not use fixture on dimming circuits.**

14. **Cut supply cable to desired length.** Strip black and white wire leads with wire strippers to expose 3/8"-7/16" of bare metal.
15. **Using Wire nuts, connect supply** (house) wires to fixture wires - white to white, black to black, and green to green or bare copper ground wire.
16. **Bundle wires in tight grouping to be out of** the way and reinstall Wireway Cover assembly

### Trouble Shooting Guide

If this fixture fails to operate properly, use the guide below to diagnose and correct the problem.

- Verify that fixture is wired properly.
- Verify that fixture is grounded correctly.
- The line voltage at the fixture is correct.

If further assistance is required, contact:

**888-896-2101**

**STEP-BY-STEP GUIDE FOR INSTALLING CHAMELEON LPAR4, LPAR8, LPAR4C AND LPAR7C**

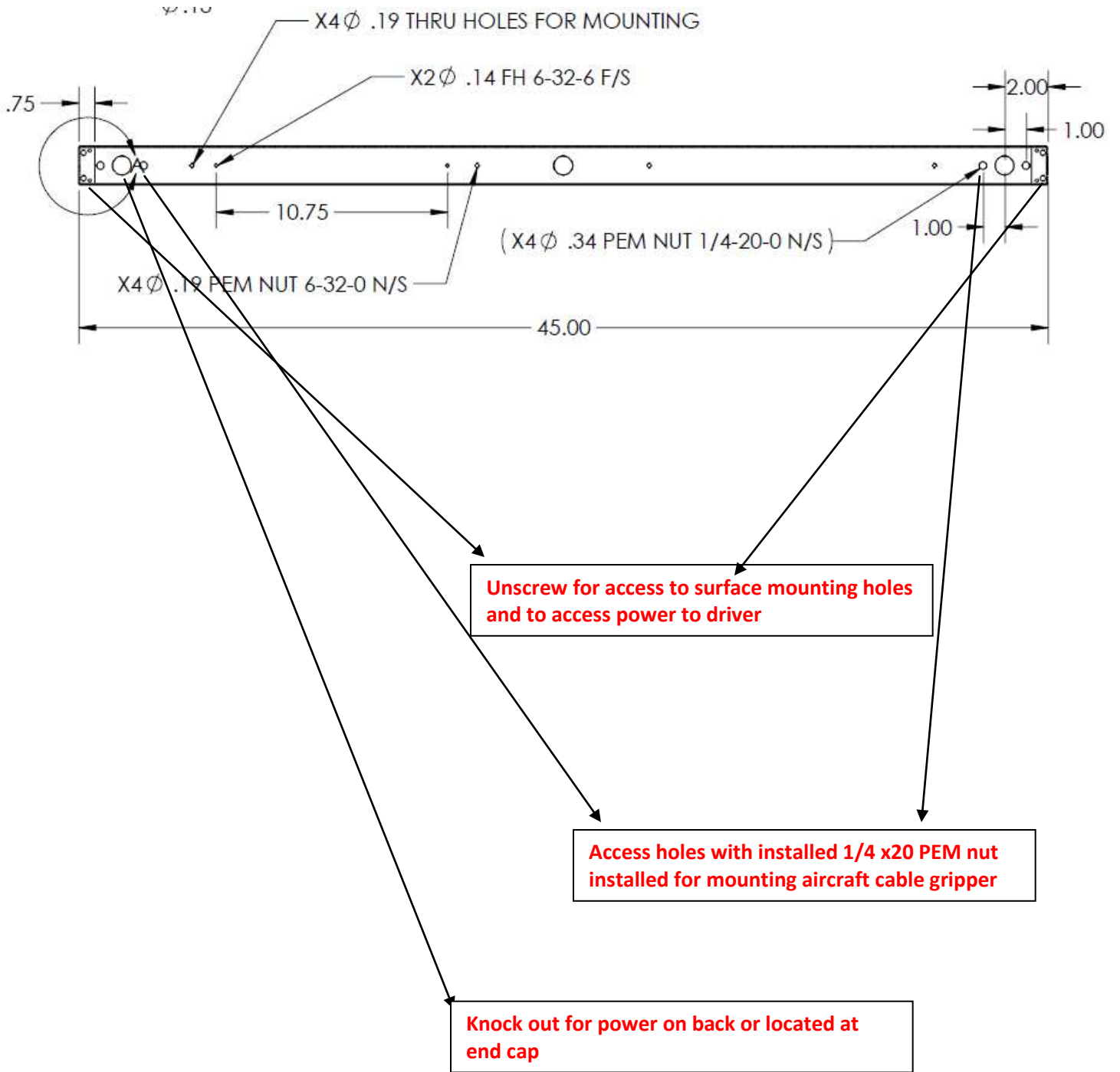

**STEP-BY-STEP GUIDE FOR INSTALLING CHAMELEON CCK-LPAR-F/NF-X**

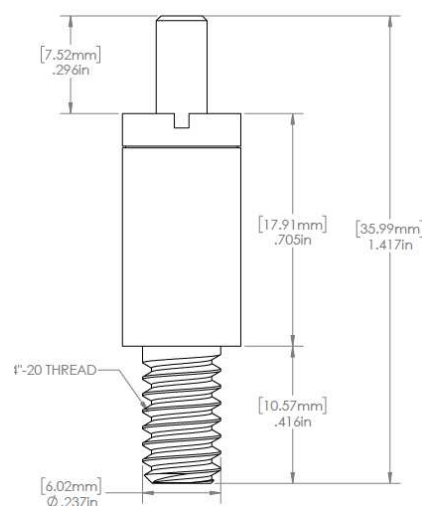
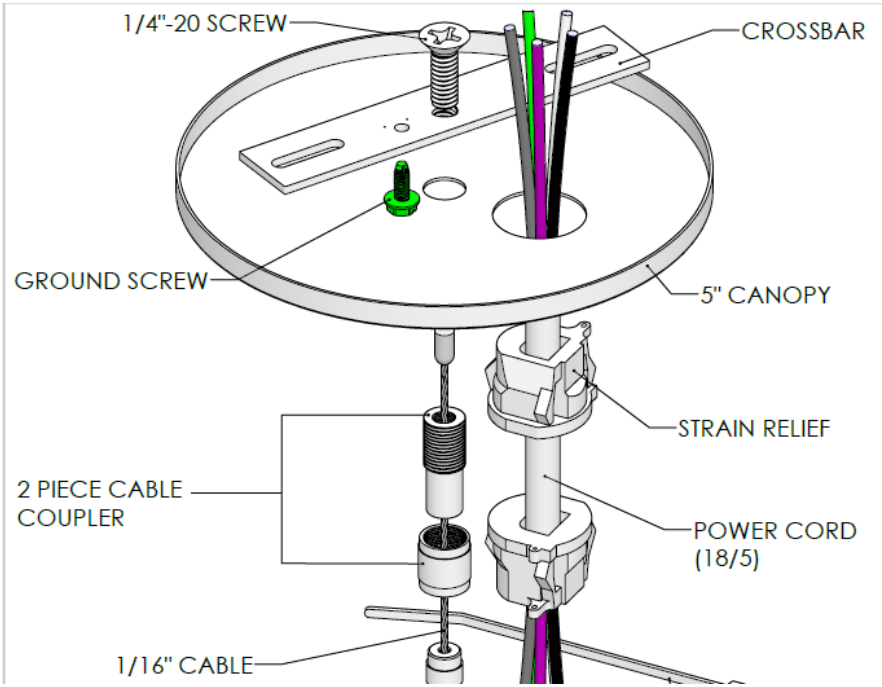

**STEP-BY-STEP GUIDE FOR INSTALLING CHAMELEON SCK-LPAR-X**

1. Attach stem to fixture though available knock out on back of fixutre.
2. Use included hardware (lock-nuts) to attach stem to fixture knock outs on back of fixture.

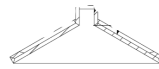

SECTION A-A

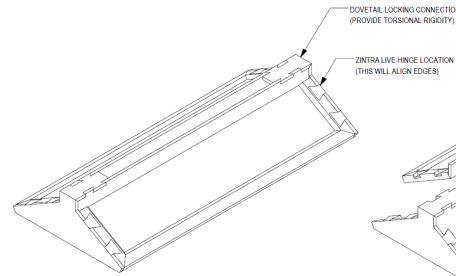
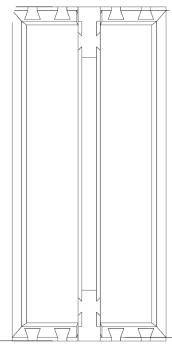

ISOMETRIC

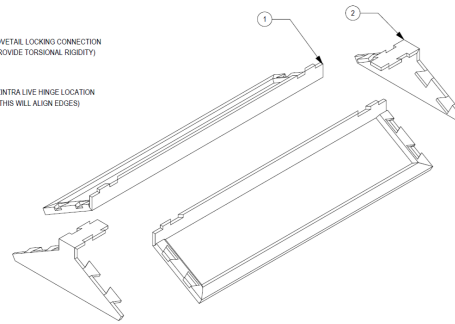

EXPLODED

Install acoustic shade prior to installing LPAR fixture. Align holes on back of LPAR for wire as well as cable suspension.