



CATALOG #

# MALIBU DRUM - SURFACE OR SUSPENDED



\*image shown surface mounted

**CONSTRUCTION:**

- Brushed Nickel Body with White Acrylic Diffuser



**LIGHT ENGINE SPECIFICATIONS:**

- Electronic Dimmable (120V) - ELV
- Direct/Indirect Light
- ETL Listed for Damp Locations (IP65)
- Performance: 3000K, 90CRI, 120V, 24 watts, 1980 Source Lumens, >82 LPW
- Low Flicker
- UL Listed for Damp Locations
- LED
- 5 Year Warranty

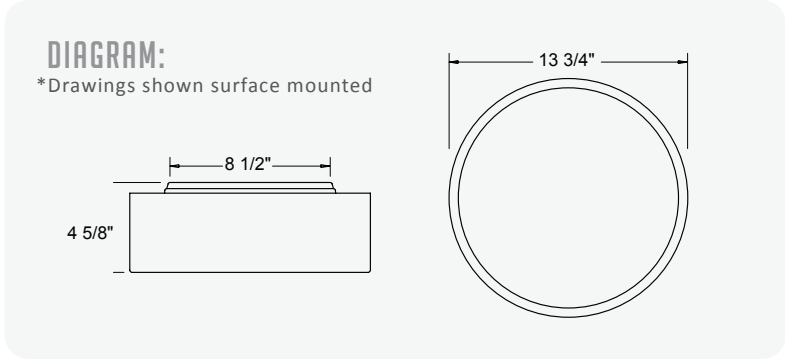

**MOUNTING:**

- Ceiling Mount
- Stem Mount - 6"/13" Pendant kit, in Brushed Nickel

## BUILD YOUR PRODUCT

Grayed areas are codes for creating your lighting catalog #  
EXAMPLE CATALOG # CMB-14-N-24W-30-9

SHADE STYLE	SIZE	FINISH	ELECTRICAL	COLOR TEMP.	CRI	MOUNTING
<input type="checkbox"/> CMB	<input type="checkbox"/> 14	<input type="checkbox"/> N Brushed Nickel	<input type="checkbox"/> 24W 24 WATTS	<input type="checkbox"/> 30 3000K	<input type="checkbox"/> 9 90 CRI	<input type="checkbox"/> SSTM Brushed Nickel Pendant <input type="checkbox"/> (blank) Surface

\*\*\* Specifications subject to change without notice.